



To build sprayer, Shaune Switzer moved engine and transmission back on school bus frame and added a combine cab.

Bus Turned Into First-Rate Sprayer

Although he only completed work on his new home-built sprayer in late April, Shaune Switzer of Sibbald, Alberta, has already done a couple thousand acres of custom work with his new machine.

Built from a schoolbus frame and power train, Switzer used the sprayer on his own cropland, before tapping into the local market for his custom work.

To build the unit, he moved the engine and transmission back on the school bus frame to make room for a cab on front, which came from a White 9700 combine.

Switzer bought a Brandt 1,000-gal. tank and a 5 hp Honda engine to power the sprayer pump.

"The steering axle is off a New Holland TR97 combine and the back driving axle is off an N5 Gleaner," he says. "I used the differential off a GMC pickup which drives into the final drives on the axle."

He built an 82 1/2-ft. boom that covers 10 acres for each mile traveled. The booms themselves are on air cushions to take out all the shock loads when spraying. To do this, he used small airbags called Load Busters from a pickup.

"The whole chassis rides on airbags, too. Those came out of a semi at a salvage yard," Switzer says. "The bus had hydraulic brakes, so I used that hydraulic pump to run the hydraulics for the boom, and also for my steering. I also got a Raven Autorate Controller to automatically vary the output of the pump, depending on speed, and this maintains whatever rate you've set it for."

He installed an Outback GPS Guidance system and has triple swivel nozzle bodies on the boom so he can change nozzles quickly. New surplus signal light switches control the boom and tip height.

"I had the sprayer commercially sand blasted before I painted it," he says.

Switzer's rig has a top speed of about 22 mph on the road and he says 18 mph in the field is pretty comfortable if it's fairly flat and open.

The whole sprayer (including paint) cost him \$20,000 (Can.).

Contact: FARM SHOW Followup, Shaune Switzer, Box 37, Sibbald, Alberta, Canada T0J 3E0 (ph 403 676-2265; email: rv8r@telusplanet.net).

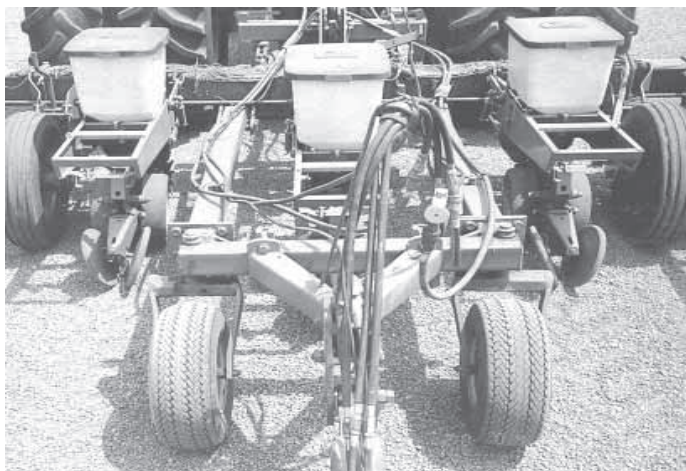

Brad Smidt created new hitch using tubing from an old anhydrous applicator and wheels from a Deere cultivator. Hitch attaches behind front planter and runs up under main frame of front planter.

Low-Cost Splitter Hitch

Brad Smidt wanted to plant narrow row soybeans without the expense of buying a new drill. So the Lennox, S. Dak., farmer used old machinery parts to build his own low-cost splitter hitch. It lets him pull two 36-in. row planters in tandem behind his tractor to plant beans in 18-in. rows.

The front planter is a Deere 7100 8-row, 30-in., 3-pt. mounted planter that he converted to a 7-row 36-in. model. He put the middle row unit behind the planter transmission.

The rear planter is a Deere 7200 8-row, 36-in. planter. The main tubing for the home-built hitch is off an old anhydrous applicator; the wheel assemblies are off a Deere 845 field cultivator; and the wheel frames are off a Deere 1240 planter. The hitch goes under the main frame of the front planter and bolts to its hitch.

"I've used this planter arrangement for six years and really like the job it does," says Smidt. "At the time I built it a new drill of comparable size would have cost \$25,000 to \$30,000. Great Plains made a 3-pt. mounted 5-row narrow planter with a hitch for use with a 6-row narrow pull-type planter, but nothing for an 8-row wide planter like I had. I



Tongue on rear planter hooks up to back of splitter hitch without modification.

used decals to label my hitch as an A7210 model, which I think is fitting because a 7100 planter is pulling a 7200 model.

"I bought the 7100 planter used for \$5,000. It was equipped with new Deere radial bean meters. I already had the 7200 planter. At the time I built the hitch I used the 7100 model only to plant soybeans, and the 7200 by itself to plant all my corn in wide 36-in. rows. I've since bought a 16-row corn planter.

"Turning around with the planter in the field is pretty simple. I just lift the mounted planter up first and then the pull-type planter and hit the brake a little on whichever side I want to turn," he notes.

Contact: FARM SHOW Followup, Brad Smidt, 27985 468th Ave., Lennox, S. Dak. 57039 (ph 605 647-5060).

Home-Built Post Puller

"It's simple in design but works better than anything I've ever tried," says Pat McGee, Eunice, La., about his home-built post puller that makes use of an old car bumper jack. It lets him jack posts out of the ground like jacking up a car.

The post puller consists of a 1/4-in. thick steel plate that's 4 in. wide by 7 1/2 in. long with three holes cut into it. A 3/4-in. dia. hole at one end of the plate is used to pull fence rods or rebar stays. A cross-shaped hole is used for T-posts. A rectangular slot hooks onto the bumper jack.

To pull out a T-post, McGee simply drops the plate over the post and then jacks it out of the ground.

"It's as easy as jacking up a car," says McGee. "I thought of the idea one evening while I was trying to pull some T-posts on electric fence lines. The bumper jack I use is out of a 1988 Chrysler, but I think the same

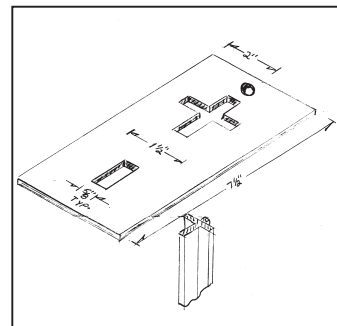

T-post fits through hole cut in steel plate.

idea could be used with any type of jack."

Contact: FARM SHOW Followup, Pat McGee, 3213 Bayou Mallet Rd., Eunice, La. 70535 (ph 337 457-4901).



Blade quick-tach to frame of 38 to 55 hp utility tractors.

Belly Blade Turns Tractor Into Grader

Farmers and ranchers everywhere can stop twisting their backs to keep an eye on rear-mounted tractor blades.

The Belly Blade from Grouser Products attaches to the frame of 38 to 55 hp utility tractors.

The tractor's hydraulic system raises, lowers, angles, tilts and side-shifts the blade. You can also adjust blade pitch which helps control the cut.

It comes in three sizes: 6 ft., 7 ft., and 8 ft. wide.

The Belly Blade fits on New Holland TC40, TC 45; Case DX 40, DX 45; and Kubota's Grand L 4330, Grand L 4630 and Grand L 5030.

All tractor models can have OEM loaders on and the blade will still work. All models right now can't be equipped with a cab.

It won't currently fit Deere and other New Holland, Case and Kubota models yet, but plans are on the drawing board to fit the

Deere 4510, 4610, 4710, 4120, 4320, 4520, and 4720; New Holland TC48 and TC55; Case DX48 and DX55; and Kubota 4800, 4900 and 5700.

The blade quick-tach to a bracket bolted to the tractor's frame. No permanent modification to the tractor is required.

Grouser adds a hydraulic control valve to the tractor. This system does not use the tractor's remote outlets.

"There isn't anything like it on the market," says Jason Faulkner, dozer sales manager of Grouser Products. He says that during the 1980's another company made a belly blade but they stopped making them in 1991. "They were ahead of their time," he notes.

The Belly Blade costs about \$8,500.

Contact: FARM SHOW Followup, Grouser Products, 755 2nd Ave. NW, West Fargo, N. Dak. 58078 (ph 800 747-6182; email: grouser@grouser.com; website: www.grouser.com).

Don't Miss The Next Issue Of FARM SHOW

Every day our editors are uncovering exciting new products and farmer-built inventions that promise to save you time and money. Don't miss out! You can tell when your FARM SHOW subscription expires by checking your address label on the front cover. It gives you the date of your final issue (example: 10/1/2004). You can use the order envelope enclosed with this issue, or the order coupon on page 44, to send in your renewal. Or call us toll-free at 1-800-834-9665.