



Chopper units positioned over each row chop material into a fine mulch that's spread evenly behind full width of machine.

RECUTTER SCREENS SHRED STALKS COMPLETELY AT 10 MPH

Fast New Way To Shred Stalks

New 3-pt. mounted over-the-row crop shredder is equipped with "star wheels" that pull crop material out from between rows and feeds it to new-style choppers positioned over each row. It chops stalks faster and more completely than any other conventional crop shredder, according to Orthman Mfg., Lexington, Neb.

Although designed for chopping stalks on ridges, the company says the new chopping units work so much faster and chop material up so much more finely than other choppers that the machine is being marketed for use with any tillage system. The new-style chopper units are equipped with flail cutters that swing inside a recutter screen, producing a fine mulch that is spread evenly behind the full width of the machine.

"The recutter screens assure more uniform cutting of crop residue which results in faster decomposition and fewer plug-up problems later," says Raul Johnson, sales manager, about the pto-powered rig. "There's no windrowing of chopped material. The combination of 3-pt. mounting and recutter screens lets you go 8 to 10 mph compared to 5 to 7 mph for conventional

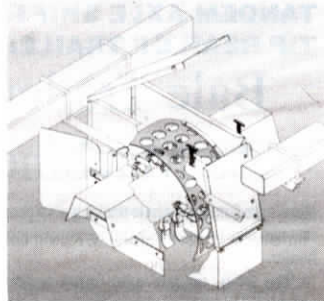

Chopper units are equipped with flail cutters that swing inside a recutter screen.

shredders."

Hinged covers on top of each cutter unit provide easy access for inspection and service.

Available in 6-row wide and 8-row narrow models. The 8-row model sells for \$13,000.

Contact: FARM SHOW Followup, Orthman Mfg., Inc., Box B, Lexington, Neb. 68850 (ph 308 324-4654).

AVAILABLE WITH ONE, TWO OR THREE HOPPERS

Gooseneck Grain Trailer Has Multiple Hoppers

They dump fast, have a low profile, and let you haul more than one variety of seed or both seed and fertilizer at the same time.

So say the manufacturers of new gooseneck grain trailers with one, two or three separate hoppers designed to let you do the work of a dump-bed grain truck with your existing pickup.

Bob Oberle of Specialty Machine designed the trailer because he's had a lot of demand from farmers who wanted a grain trailer they could pull at road speeds. "Most dump-bed grain trucks sit idle 50 weeks out of the year," he notes.

The tandem axle trailer is designed for road hauling, not in-field work. You can pull it with a 3/4 or 1-ton pickup. It's fitted with from 1 to 3 hoppers of 150 or 200 bu. each. Maximum hauling capacity is 600 bu.

"Farmers like the multiple hoppers be-

cause they can haul more than one variety of seed or grain, and when seeding they can carry seed in one hopper and fertilizer in the other," says Oberle's wife and partner, Linda. Having multiple hoppers also gives the trailers a low profile for better roadability, and the trailer can be dumped in less than a minute at the elevator. "The best thing is that it sells for about one-third the cost of a similar capacity dump bed truck," she says.

A 400-bu., 2-hopper trailer sells for \$9,750, fitted with electric brakes. It can also be fitted with hydraulic or air brakes. It's got two 12,000-lb. axles and stands just 74 in. high. Double reduction jacks make handling easy.

For more information, contact: FARM SHOW Followup, Specialty Machine & Mfg. Inc., 9th & Patton, P.O. Box 85, Great Bend, Kan. 67530 (ph 316 793-5467).



Trash Wheels clear residue in front of each planter opener, creating a garden-like seedbed in heavy residue.

PAIRS OF INTERSECTING STEEL WHEELS CLEAR RESIDUE FROM A 4 TO 6 IN. ZONE

"Trash Wheels" Clear And Till Seedbed

"It clears residue from a 4 to 6 in. wide zone in front of your planter, allowing you to plant into standing unchopped cornstalks and lightly tills the soil to create a garden-like seedbed," says Jim Bassett, president, Dawn Equipment Co., DeKalb, Ill., about the company's new "Trash Wheels" for row crop planters.

Trash Wheels, which bolt onto the planter row unit, consist of pairs of free-turning, ground-driven steel wheels that till and clear a path for each planter opener. The intersecting wheels self-clean themselves.

"Other trash clearing units sweep trash aside without tilling the ground, and most have no depth control relative to the V-opener," says Bassett. "Our goal is to eliminate spring tillage. We've tested Trash Wheels on over 18,000 acres over the past three years under no-till, minimum till, and ridge-till conditions. They're a big improvement over no-till coulters, which just slice through residue but don't sweep it out of the way. Getting residue out of way improves depth control and chemical effectiveness."

An optional "Quicklift" mounting system lets you quickly raise and lower the units when changing from no till to conven-

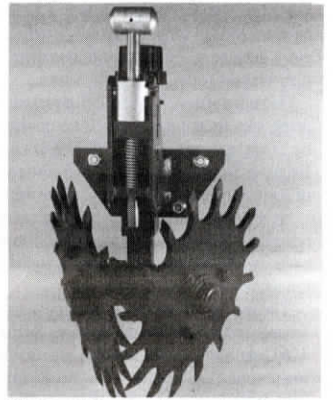

"Quick lift" mounting system lets you quickly raise and lower units when changing from no till to conventional planting.

tional planting or on headlands.

Sells for \$179 per row. The Quicklift option costs \$120 per row. The screw adjust option costs \$56 per row.

Contact: FARM SHOW Followup, Dawn Equipment Co., 1913 W. Fairview Drive, DeKalb, Ill. 60115 (ph 815 756-1801).



Multiple hoppers let you haul both seed and fertilizer at the same time.